

DWG.NO. HW1385424

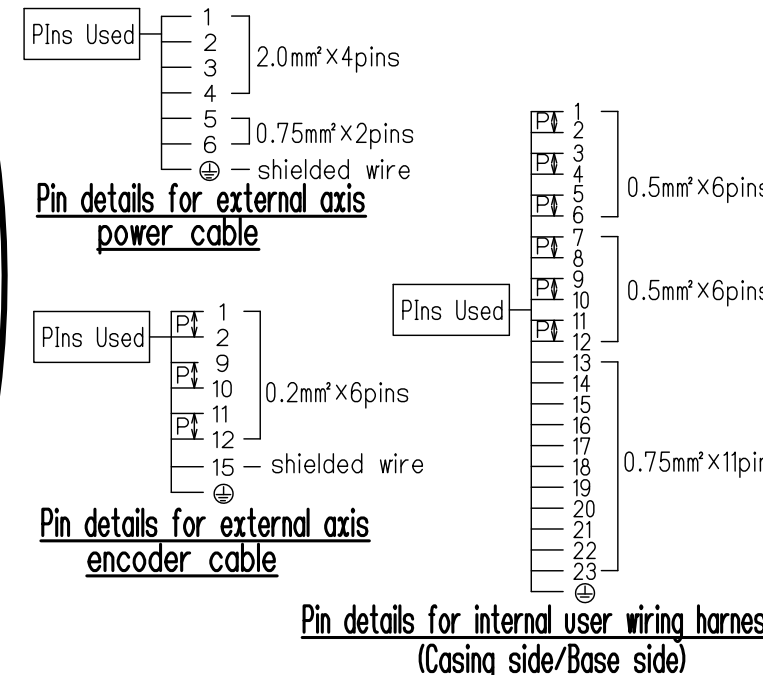

View A (Scale 1:15)

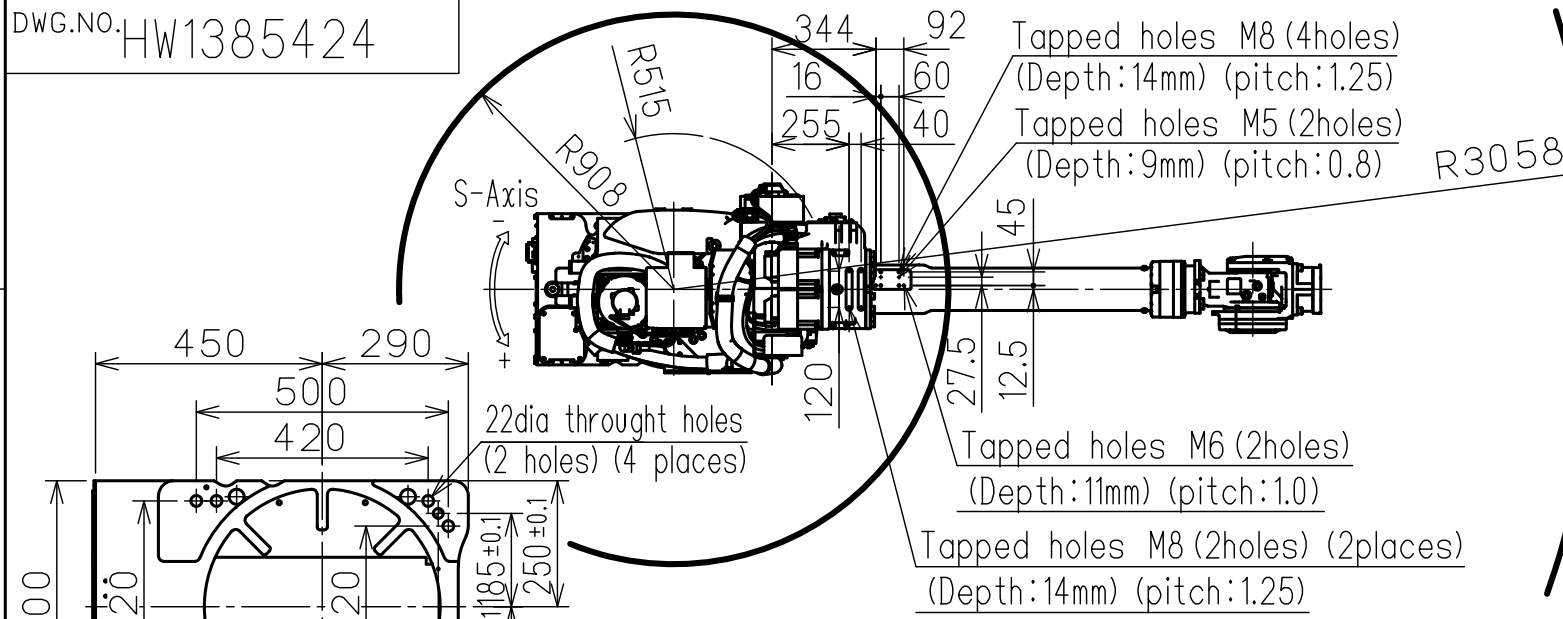
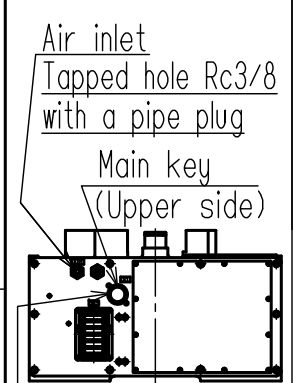

View C (Scale 1:15)

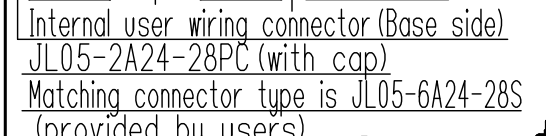

Type	Note
YR-1-06VX180-120-A00	Payload 120kg, U-arm long

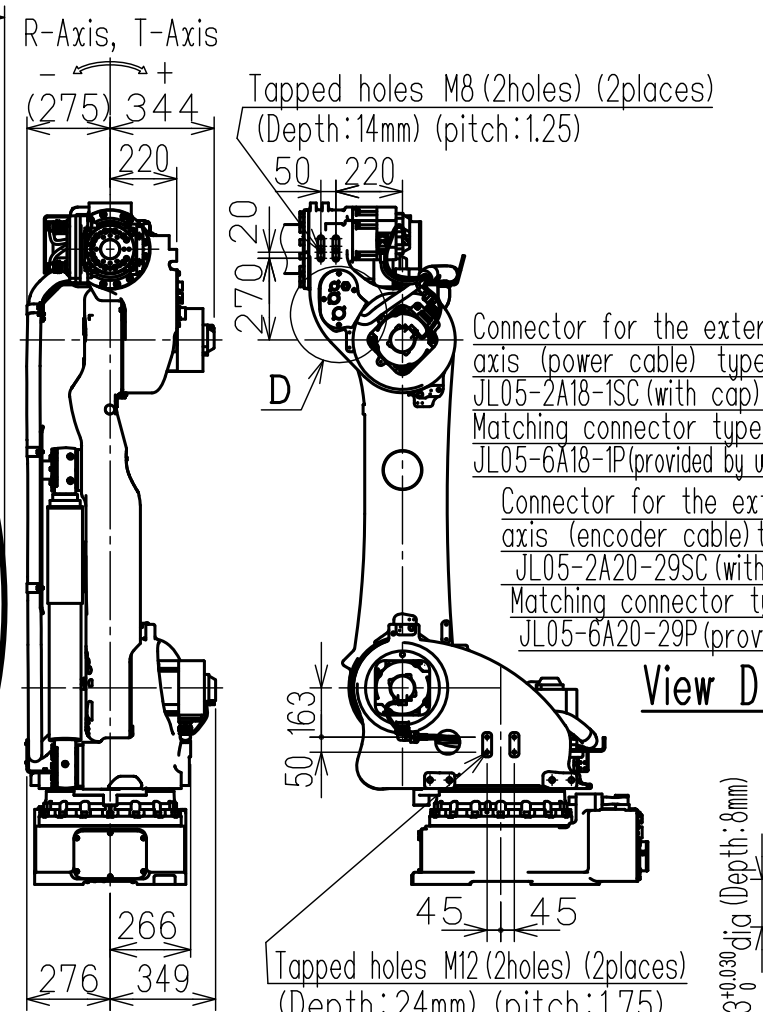

View D (Scale 1:15)

View B (Scale 1:10)

Item	Model	MOTOMAN-GP180-120
Configuration		Vertically articulated
Degree of Freedom		6
Payload	Wrist	120kg
	On U-arm	30kg
Repeatability (※1)		±0.2 mm
Range of Motion	S-Axis (Turning)	-180° - +180°
	L-Axis (Lower Arm)	-60° - +76°
	U-Axis (Upper Arm)	-86° - +90°
	R-Axis (Roll)	-360° - +360°
	B-Axis (Pitch/Yaw)	-130° - +130°
Max Speed	S-Axis	2.18 rad/s, 125°/s
	L-Axis	2.01 rad/s, 115°/s
	U-Axis	2.18 rad/s, 125°/s
	R-Axis	3.18 rad/s, 182°/s
Allowable Moment	B-Axis	883 N·m (90 kgf·m)
	T-Axis	520 N·m (53 kgf·m)
	R-Axis	883 N·m (90 kgf·m)
Allowable Inertia (GD <sup>2</sup> /4)	B-Axis	79 kg·m <sup>2</sup>
	T-Axis	40 kg·m <sup>2</sup>
	R-Axis	79 kg·m <sup>2</sup>
Approx. Robot mass		1090kg
Protected structure		Body:IP54 Wrist:IP67
Mounting method		Floor-mounted
Ambient Conditions	Temperature	0 to +45°C
	Humidity	20 to 80%RH (Non-condensing)
	Vibration	4.9m/s <sup>2</sup> (0.5G) or less
	Altitude	1000m or less
	Others	•Free from explosive or corrosive gas and liquid. •Free from dust, soot, oil, or water. •Free from electrical noise. •Free from strong magnetic fields.
Power Requirements		5.0kVA
Controller		YRC1000

※1 Repeatability is conformed to ISO 9283.  
 ※2 The manipulator is in the home position.  
 Units: mm

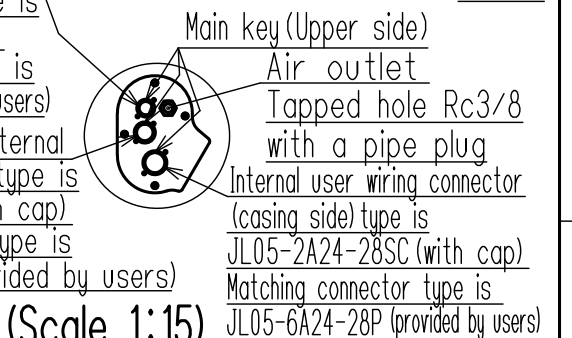

Note:  
 1.All rights reserved.  
 2.Please note that the data is subject to be deleted without advance notice.  
 3.No warranty is given in relation to the data including the specification.  
 4.We are not responsible for any damages or loss caused by the use of the data.

FOR STUDY PURPOSE ONLY

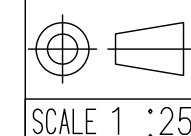

**YASKAWA**  
 株式会社安川電機

Reference Drawing

TITLE MOTOMAN-GP180-120  
 DIMENSION DIAGRAM

DRWN DATE Oct.03.'17  
 DWG.NO. HW1385424

SIZE A3